

# **Section 3**

## **Lower Engine Mount**

---

**Procedures covered in this section:**

Drill airframe bushings; install lower engine mount and rubber ring; install fuel system mount tube.

**Cards used in this section:**

E13 CARD 1T

**Prints used in this section:**

E13-2000

**Templates used in this section:**

E13-1

**Tools Required for this section:**

|                       |        |              |
|-----------------------|--------|--------------|
| Air or electric drill | Files  | Mallet       |
| Band saw or hacksaw   | Hammer | Tape measure |
| Drift punch           | Level  |              |

Drill bits of the following sizes: 3/16", 5/16"

Ratchet with sockets of the following sizes: 3/8", 1/2"

Wrenches of the following sizes: 3/8", 1/2"

**Notes:**

1. SHIMS: Do not cut out shims for the engine mount at this time. When engine is ready to be installed, determine which shims are needed and cut out only what is necessary. (See Section 12.)



**Photo #1**

Drill the four lower engine mount bushings on the airframe using a 5/16" drill bit.

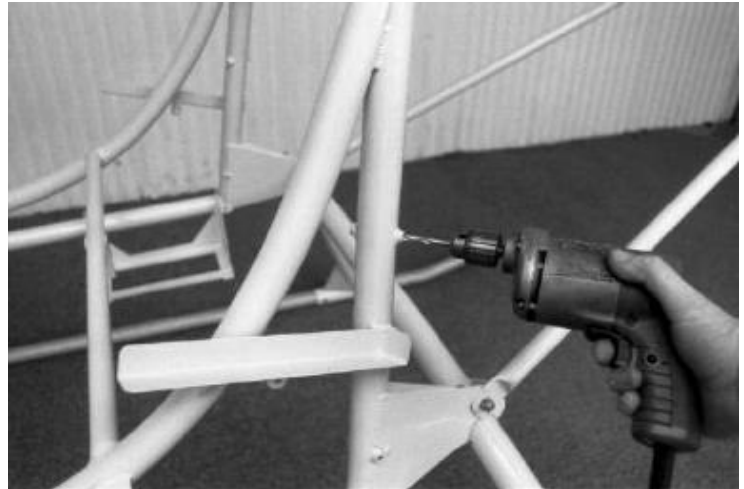

**Photo #2**

To fit the engine mount, level the airframe fore/aft and laterally at the square drive mount tubes. Bolt the support ring to the engine mount weldment. Shorten the lower bushings to fit, then bolt the lower arms of the engine mount to the airframe. Hang a plumb line from the square tubes to locate the center of the support ring. Shorten the upper and/or lower airframe bushings to achieve the following:

The support ring must be centered.

The distance from the top of the engine mount plate to the bottom of the square drive tubes should be approximately 24".

The engine mount plate and support ring must be level within plus or minus 1/4 degree.

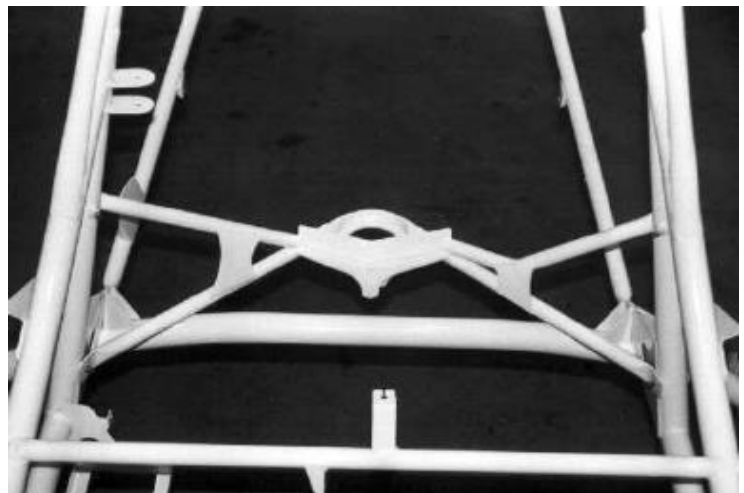
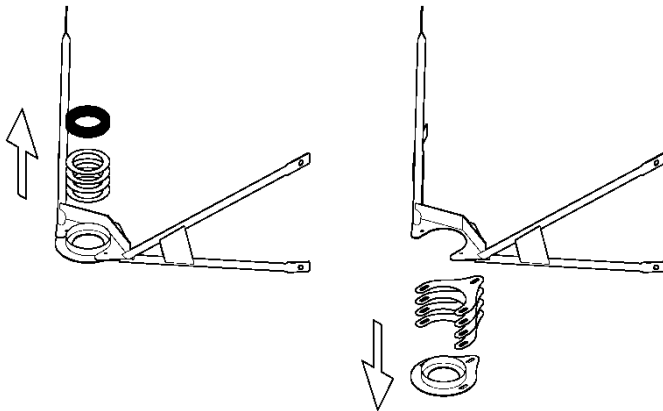

**Photo #3**

When located correctly, drill the bolt holes in the upper arms of the engine mount, using the airframe bushings as a guide. The holes do not have to be exactly centered on the flat part of the arm, but maintain correct edge distance (minimum 1-1/2 times hole diameter) when drilling.

Note: If necessary, material can be removed from the bushings up to 1/16 inch away from the weld. A spot face drill works well for this procedure. On each bushing, the ends must be 90 degrees to the hole.





**Photo #4**

Shims will be installed later to change the height of the engine. Add "O" shaped shims between the engine mount and the rubber to raise the engine, OR add "Y" shaped shims between the engine mount and the support ring weldment to lower the engine. (See template E13-1.) Do not cut out shims at this time, but wait until installing engine to determine which shims are needed. (See Section 12 page 4).

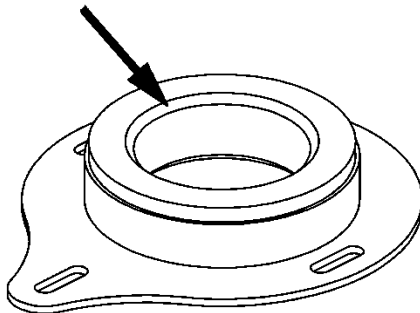

**Photo #5**

Chamfer the inside edge of the engine mount rubber ring (arrow) so that when the engine is installed, it will seat completely on the ring. Then install the rubber ring in the support ring weldment.

Note: When the engine is installed the engine should sit on top of rubber ring. If mount rubber ring is too tight on engine, remove material from outside of rubber ring to allow more inside clearance.

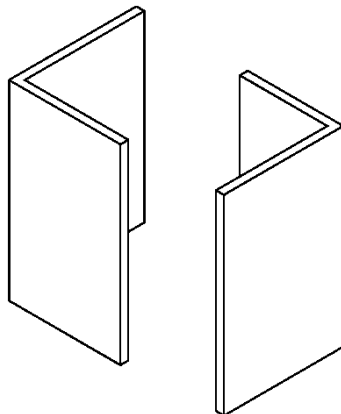

**Photo #6**

Cut the 1" square tube into two pieces to make the tabs for the fuel system mount tube.

Note: This square tube and all related hardware is found on E10 CARD 1.

**Photo #7**

Bolt the tabs to the rear landing gear brackets in the approximate location shown. (The exact location is not critical, but it is important to maintain clearance between the fuel system mount tube and the engine mount.)

Note: When drilling these holes, drill only through the inner plate of the landing gear bracket. Install the bolts from inside the bracket.

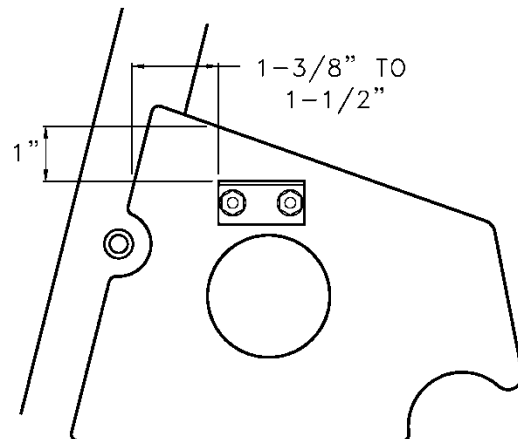

**Photo #8**

If necessary, trim the ends of the fuel system mount tube to fit. The short tube should be on center. Trim the ends so that they are equal distances from the short tube.

Note: The sump mounting strap is also shown in this photo. It will be mounted later.



**Photo #9**

Bolt the tube to the tabs as shown. When the wiring harness is installed (later), the lower outside bushing on the passenger side must be shortened to allow for battery cable ends and ground wires. For a good ground, paint removal is necessary on bushing and both sides of lower passenger engine mount tube.

